

Battery Cables — 4.0L SOHC

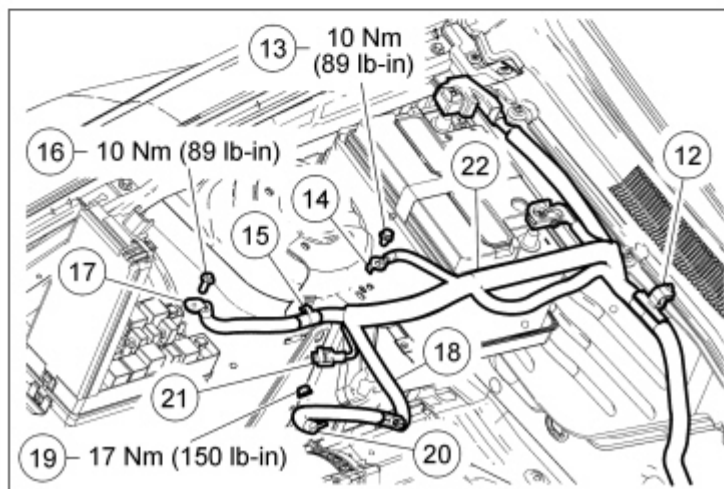
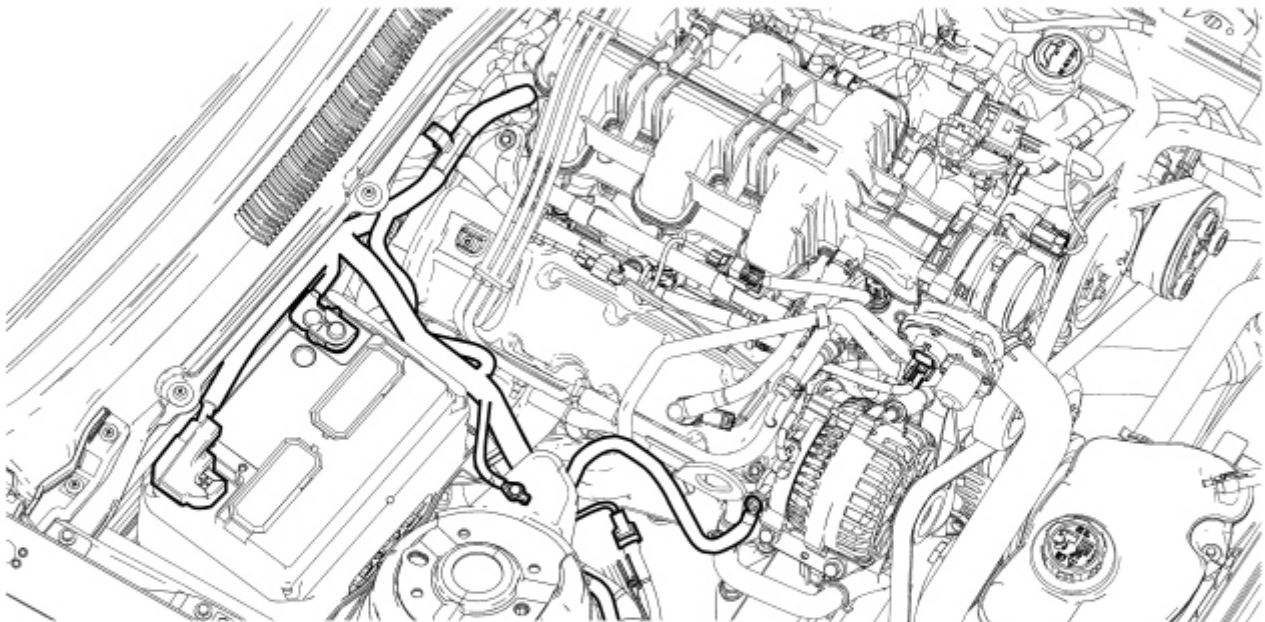
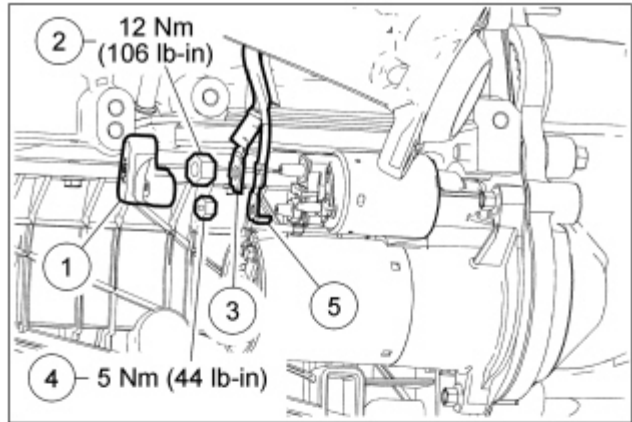
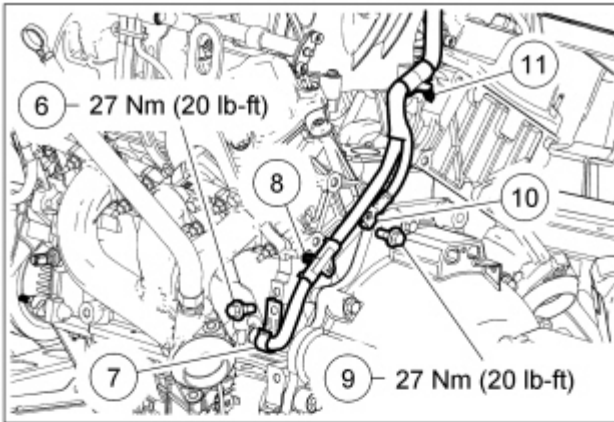

N0089221

Item	Part Number	Description
1	11N087	Starter solenoid terminal cover
2	W706414	Starter solenoid positive cable terminal nut

3	—	Starter solenoid positive cable terminal (part of 14300)
4	W705790	Starter solenoid wire terminal nut
5	—	Starter solenoid wire terminal (part of 14300)
6	W506031	Battery cable harness bracket bolt
7	—	Battery cable harness bracket (part of 14300)
8	—	Battery cable harness locator (LH) (part of 14300)
9	W506031	Battery ground cable engine terminal bolt
10	—	Battery ground cable engine terminal (part of 14300)
11	—	Battery cable harness locator (RH) (part of 14300)
12	—	Battery cable harness locator (part of 14300)
13	W712583	Battery ground cable body terminal bolt
14	—	Battery ground cable body terminal (part of 14300)
15	—	Battery cable harness locator (part of 14300)
16	—	Bussed Electrical Center (BEC) terminal bolt
17	—	BEC terminal (part of 14300)
18	—	Battery cable harness locator (part of 14300)
19	W711953	Generator B+ terminal nut
20	—	Generator B+ terminal (part of 14300)
21	—	Battery cable in-line connector (part of 14300)
22	14300	Battery cable

Removal and Installation

1. With the vehicle in NEUTRAL, position it on a hoist. For additional information, refer to [Section 100-02](#).
2. Disconnect the battery. For additional information, refer to [Battery Disconnect](#) in this section.
3. Remove the starter solenoid terminal cover.
4. Remove the nut and position the starter solenoid positive cable terminal aside.
 - To install, tighten to 12 Nm (106 lb-in).
5. Remove the nut and position the starter solenoid wire terminal aside.
 - To install, tighten to 5 Nm (44 lb-in).
6. Remove the bolt and position the battery cable harness bracket aside.
 - To install, tighten to 27 Nm (20 lb-ft).
7. Remove the battery cable harness locator from behind the LH cylinder head.
8. Remove the bolt and position the battery ground cable engine terminal aside.
 - To install, tighten to 27 Nm (20 lb-ft).
9. Remove the battery cable harness locator from behind the RH cylinder head.
10. Remove the battery cable harness locator from the bulkhead.
11. Remove the bolt and position the battery ground cable body terminal aside.
 - To install, tighten to 10 Nm (89 lb-in).
12. Remove the battery cable harness locator from the RH strut tower.

13. Open the Bussed Electrical Center (BEC) cover, remove the bolt and position the [BEC](#) terminal aside.
 - To install, tighten to 10 Nm (89 lb-in).
 14. Remove the battery cable harness locator from the engine bracket.
 15. Position aside the generator B+ boot, remove the nut and position the generator B+ terminal aside.
 - To install, tighten to 17 Nm (150 lb-in).
 16. Disconnect the battery cable in-line connector.
 17. Remove the battery cables.
 18. To install, reverse the removal procedure.
-